

Instrument Enclosure System

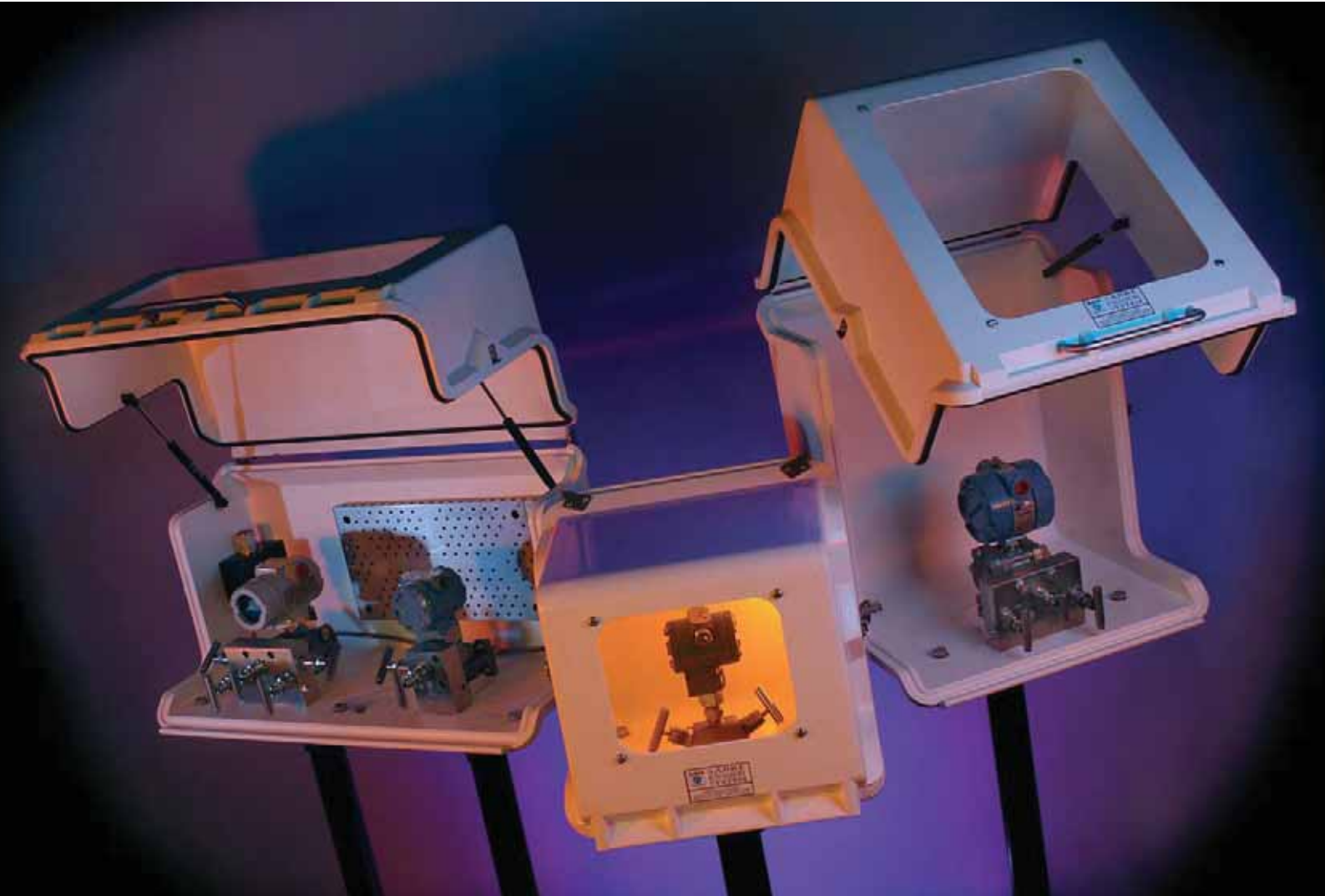

Sabre



Sabre Instrument Enclosures

Contents	Page
Introduction	2
Enclosure System	
Specifications	3
Features	4
IEX1 Enclosure	4
IEX2 Enclosure	5
IEX3 Enclosure	5
Enclosure Manifolds	
HMX1 & HMX2 - 2 Valve Manifolds	6
HMX3 - 3 Valve Manifold	7
HMX5 - 5 Valve Manifold	7
Process Connections	7
Manifold Mounting Options	8
Accessories	
Viewing Windows, Cable Entries & Ventilation	9
Heating & Insulation	10
Enclosure Mounting Options & Internal Instrument Mounting	11
Sunshades	
SX1, SX2, SX3 & SX4	12
Soft Enclosures	13
Enclosure System Options	14
Model Numbering System	15

Introduction

The ever increasing sophistication of process instrumentation equipment demands the highest standards of asset protection. Operators need to ensure that process integrity is maintained throughout a wide range of environmental conditions, many of these hostile and extremely damaging to unprotected equipment.

To help achieve this objective Sabre has developed a range of high specification instrument enclosures and associated instrument protection products.

The Sabre Instrument Enclosure range offers a number of key benefits to the process operator, not least robust construction, advanced materials technology and a choice of equipment options designed to withstand the harshest of application environments.

Sabre enclosures protect electronic, mechanical, hydraulic and pneumatic instruments and associated equipment from the damaging effects of high winds, rain, snow and sub-zero conditions, both onshore and offshore, so extending their operational life, protecting capital investment and minimising equipment maintenance and service costs. Process

measurements are maintained at consistent levels through the thermal stability offered by the enclosure.

All Sabre enclosures incorporate a number of features designed to promote long life and ease of use. Enclosure bodies are manufactured from high strength materials using precision mould press tooling to ensure repeatability and a close tolerance fit. All metal goods are made from corrosion resistant materials and gas strut technology is employed to provide a smooth and controlled opening and closing action.

Enclosures can be fitted with a number of options including: viewing windows, heaters/thermostats, vents, and thermal insulation materials and are able to accommodate a comprehensive range of integral base or back mounted instrument manifolds.

Sabre has extensive experience in the factory fitting of free-issue instrumentation - so supplying complete, ready-to-use units directly to site. This results in lower overall costs, improved installation times and reliable system integrity.

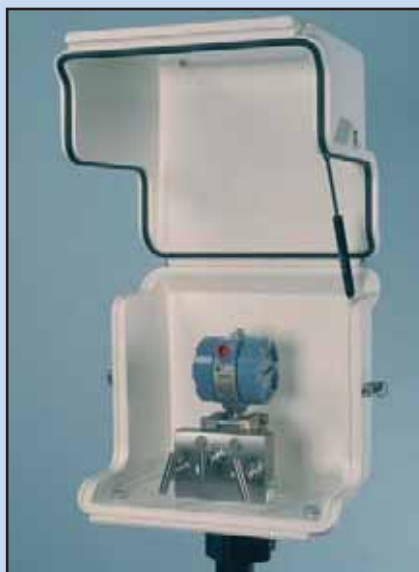

Specifications

Sabre enclosures are available in a variety of standard sizes and configurations, designed to accommodate a wide range of single and multiple instrument arrangements. The modular nature of the Sabre Enclosure System ensures that equipment protection is optimised, so providing reliable and consistent data feedback from field instrumentation even in the most hostile conditions.

GRP Construction

Sabre enclosures are constructed from two identical high strength Glass Reinforced Polyester mouldings produced using precision press mould tooling. Materials used ensure that the enclosure is fire retardant to BS 476 Part 7 Class 2.

Side Loaded Hinges

Stainless steel hinges are integrally moulded into the enclosure design so providing for a strong and robust connection. The hinge design allows for easy removal and reassembly of the enclosure lid should this be required.

Toggle Latches

Stainless steel toggle latches are used as standard. The 'over-centre' action of this latch type ensures superior sealing between the enclosure lid and base and, together with the integral hinge design, maintains a full contact seal along the total length of the mating joint.

Enclosure Mating Joint Seal

The mating joint seal is manufactured from closed cell neoprene. The seal is mounted in the enclosure lid to ensure that it is not accidentally damaged by the operator when in the open position. The combination of the hinges, latches and joint seal provides the enclosure with an IP66 rating as standard.

Gas Propstays

Opening and closing of the enclosure assembly is controlled by gas loaded propstays similar to those in common use throughout the automotive industry. This enables single handed operation even in high wind conditions and prevents accidental closing of the enclosure lid, protecting both operator and equipment.

Anti-static Protection

For applications which require anti-static protection enclosures can be supplied in materials which meet the requirements of BS 5501 Part 1 in respect of anti-static charges. The enclosure colour is black as standard, though other colour options are available.

Temperature Control

Enclosure systems can be supplied with electrical or steam heaters to allow for control of the internal ambient temperature. Thermostats can be used to regulate and control the operation of the electrical heater.

Extreme Condition Insulation

Heat retention can be improved further by lining the internal surfaces of the enclosure with 20mm thick insulation board materials. Insulation of enclosures also reduces the required heater rating.

Baseplates and Brackets

Baseplates and brackets are supplied as standard in carbon steel with epoxy paint finish, with stainless steel available as an option for more severe applications.

Purpose Designed Instrument Manifolds

Sabre offers a full range of 2, 3, and 5 valve instrument manifolds designed specifically for installation within an enclosure. These may be base or back mounted and are suitable for all types of pressure and D.P. transmitters. The unique split joint design of the Sabre enclosure allows full all-round access to manifolds and transmitters/instruments.

Sabre Enclosure System

Features

Precision GRP mouldings

- Superior mechanical, thermal and chemical protection
- Robust construction for long life
- Unique off-set split joint design allows for easy access for instrument maintenance
- Integral hinge, handle and seal mounting
- Standard white (with other colour options available)
- Anti-static option to BS 5501 Part 1 (standard black)

Side-Loaded Hinges

- Stainless steel as standard
- Strong hinge joints
- Easy removal & re-assembly of lid

Toggle Latches

- Stainless Steel as standard
- Positive latch locking operation
- Uniform sealing contact along joint line

Temperature Control

- Full range of insulation and heater control options
- Maintains ambient temperature for instruments

Enclosure Joint Seal

- Closed cell construction prevents deterioration
- Improved profile 'memory' - high sealing repeatability
- Lid mounting reduces risk of damage
- Provides IP66 rating

Viewing Windows

- Enable instrument reading and observation from outside

Gas Propstays

- Controlled smooth action opening and closing
- Single handed operation
- Reduces risk of accidental closing
- Protects operator and equipment from damage

Instrument Manifolds

- Designed to minimise space requirements
- 2, 3 & 5 valve options in stainless steel as standard
- Other materials available to suit the process
- NACE compliant
- Process connections made from outside the enclosure

Sabre can supply complete instrument enclosure solutions to cope with the most arduous of conditions. Optional factory fitting of transmitters and other instruments is available, so ensuring that ready-to-use enclosure systems are delivered to site, reducing lead-times and procurement and installation costs.

IEX1 Enclosure

The IEX1 enclosure has been designed for single instrument applications.

The enclosure includes as standard:

- Identical GRP lid and base mouldings
- Stainless steel hinges and toggle latches
- Closed cell neoprene seal
- Gas propstay

Options include:

- Full range of manifolds, base or back mounted
- Anti-static
- Insulation
- Temperature control equipment
- Viewing window

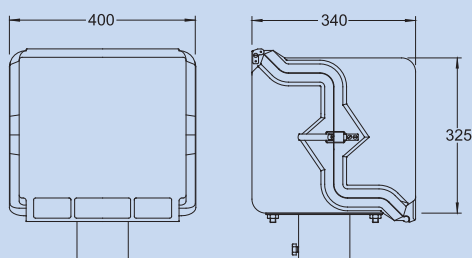

IEX2 Enclosure

The IEX2 enclosure has been designed for larger single instrument applications or smaller instruments combined with local gauges or other accessories.

The enclosure includes as standard:

- Identical GRP lid and base mouldings
- Stainless steel hinges and toggle latches
- Closed cell neoprene seal
- Gas propstay

Options include:

- Full range of manifolds, base or back mounted
- Anti-static
- Insulation
- Temperature control equipment
- Viewing window

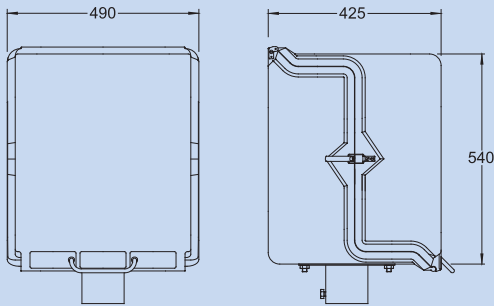

IEX3 Enclosure

The IEX3 enclosure has been designed for multiple instrument installations or small instrument control panels and systems.

The enclosure includes as standard:

- Identical GRP lid and base mouldings
- Stainless steel hinges and toggle latches
- Closed cell neoprene seal
- Gas propstays

Options include:

- Full range of manifolds, base or back mounted
- Anti-static
- Insulation
- Temperature control equipment
- Viewing window

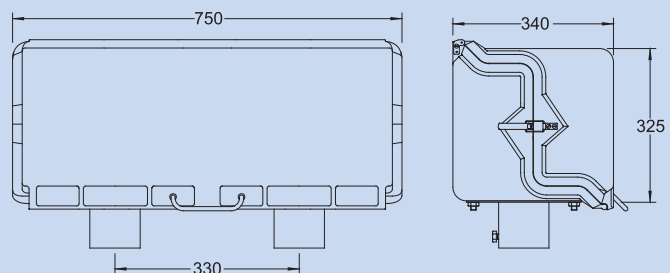

Sabre Enclosure Manifolds

HMX1 HMX2 HMX3 HMX5

The Sabre range of enclosure manifolds are specifically designed for use within Sabre enclosures. Base or back mounted to the enclosure, with all process connections made from the outside, they are suitable for direct mounting D.P. and single pressure transmitters. Supplied with PTFE seal rings and transmitter mounting bolts as standard.

2 Valve Manifold

HMX1

Application

For static pressure measurement with D.P. style, absolute and gauge pressure transmitters.

Description

- A compact 2 valve manifold designed to accommodate larger gauges within the IEX1 enclosure combining isolating, calibrating and venting facilities in a single unit.
- Provided with threaded instrument connection for direct mounting instruments.

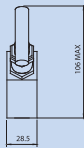
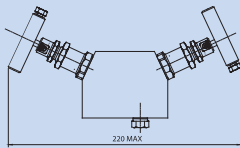

2 Valve Manifold

HMX2

Application

For static pressure measurement with D.P. style, absolute and gauge pressure transmitters.

Description

- A 2 valve manifold combining isolating, calibrating and venting facilities in a single compact unit.
- Provided with instrument flange mounting detail as standard, also available with threaded instrument connections for remote mounting instruments.
- Also available with integral steam channel, for greater heat transfer.

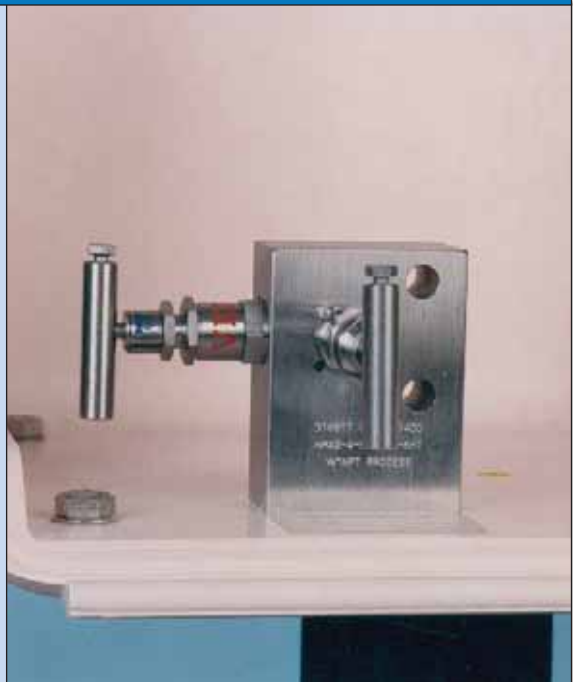
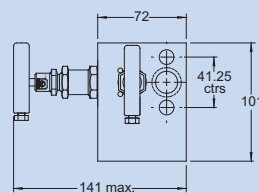
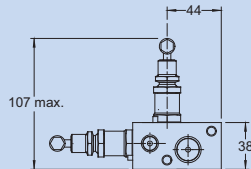

3 Valve Manifold

HMX3

Application

For general liquid and gas measurement applications using D.P. transmitters.

Description

- A 3 valve manifold combining 2 isolating and 1 equalising valves in a single compact unit providing easy instrument isolation and zeroing.
- Provided with instrument flange mounting detail on 54mm centres (other centre distances are available on request).
- Also available with integral steam channel, for greater heat transfer.

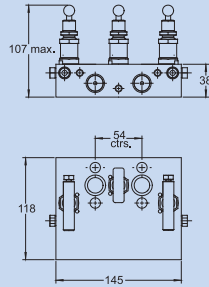

5 Valve Manifold

HMX5

Application

For general liquid and gas measurement applications using D.P. transmitters.

Description

- A 5 valve manifold combining 2 isolating, 1 equalising and 2 vent valves in a single compact unit providing easy instrument isolation and zeroing and venting.
- Provided with instrument flange mounting detail on 54mm centres (other centre distances are available on request).
- Also available with integral steam channel, for greater heat transfer.

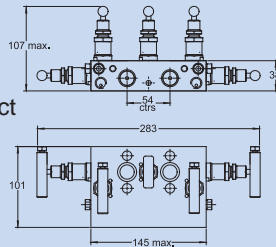

Process Connections

The Sabre enclosures are designed to enable all process connections made from the outside of the enclosure. This eliminates the need for extra bracketing and reduces installation and maintenance costs.

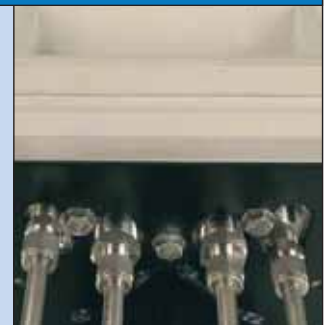

Sabre Enclosure Manifolds

Manifold Mounting Options

The Sabre range of enclosure manifolds are specifically designed for use with Sabre enclosures. Base and back mounted to the enclosure with all process connections made from the outside they are suitable for direct mounting single pressure and differential pressure transmitters. Base mounted as standard but available in high or low back mounted options for gas or liquid applications.

IEX1

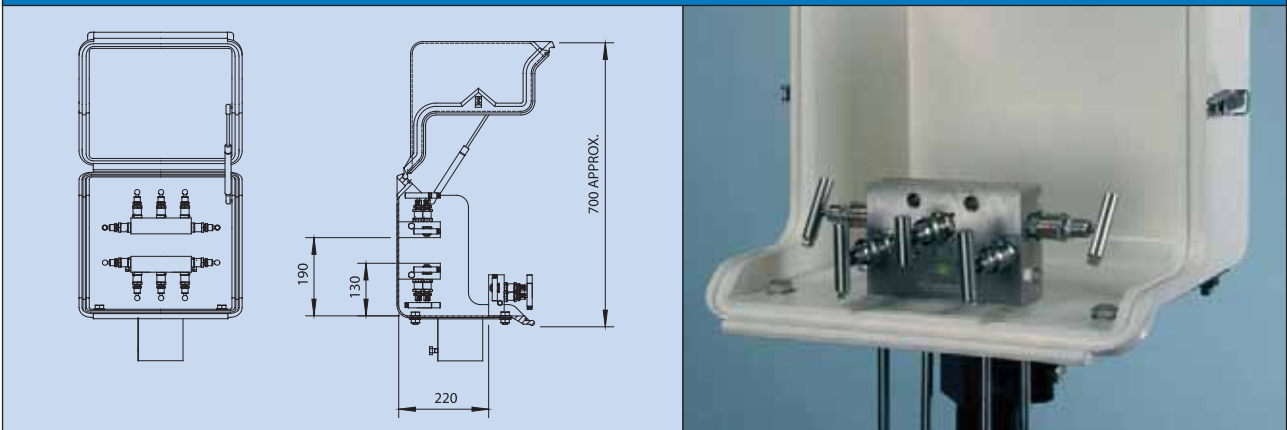

IEX2

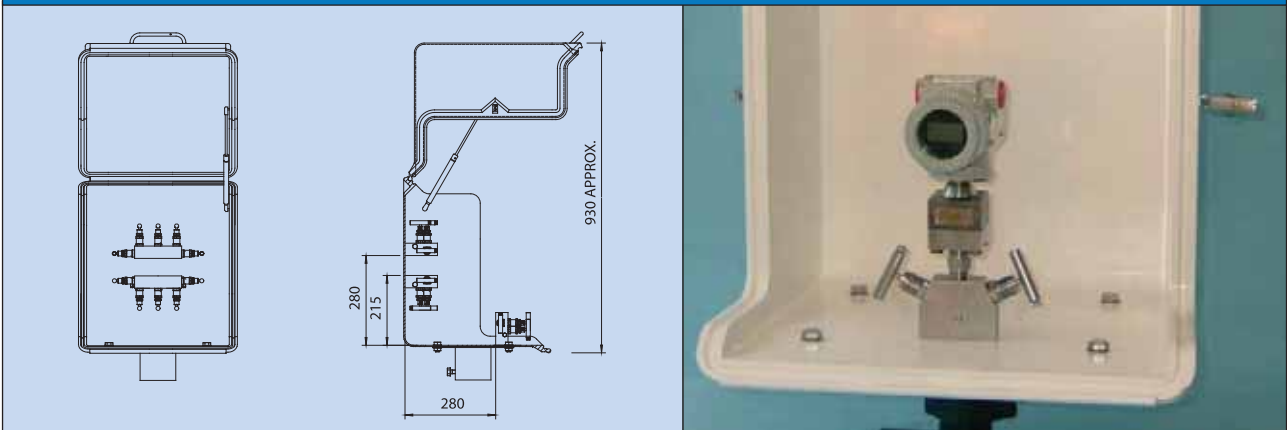

IEX3

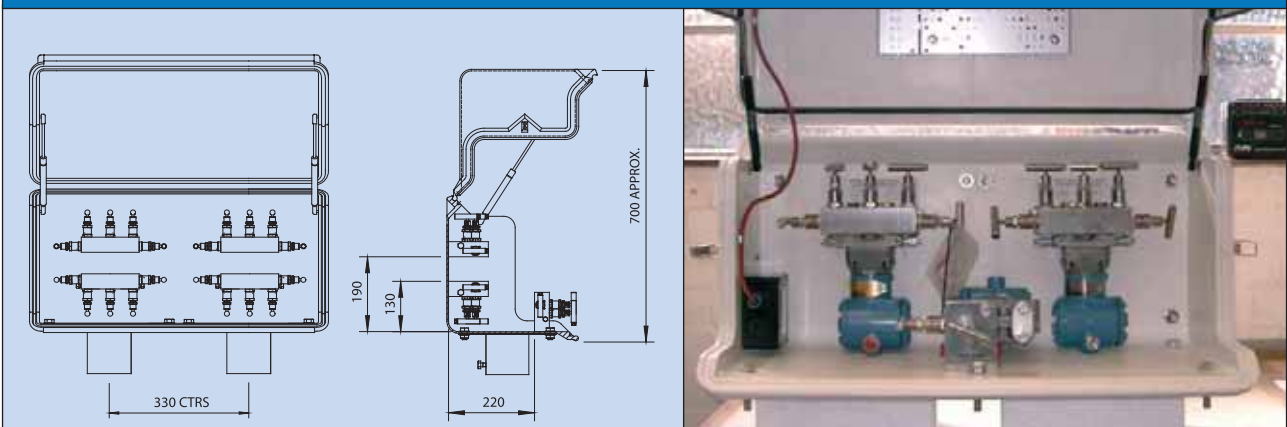

Viewing Windows

To enable external viewing of the instrument or gauge indicator Sabre enclosures can be supplied complete with integral viewing windows. The standard acrylic window is mechanically secured with a silicon seal preventing ingress of dust and other contaminants. For anti-static enclosures a laminated safety glass window is fitted as standard, secured by a pre-formed rubber sealing strip.



Cable Entries

Grommets

Available in various sizes to suit diameter of component.

Cable Glands

Supplied to suit customers' specification.

Gland Plates

Supplied fitted to side or rear of enclosure complete with seal as either a blind plate or fitted with glands, grommets, bulkheads etc.

Split Gland Plates

Enables the installation of capillary type instrument process tubing or multiple cables and incorporates a split plate design together with protective grommets.



Ventilation

Ventilators

Plastic weir type ventilator, supplied singly or in pairs to give through flow.

Louvres

Stainless steel louvres with mesh bushing to prevent insect access, supplied singly or in pairs to give through flow.



Sabre Accessories

Heating

Steam Heating - Integral

Sabre 2, 3 & 5 valve manifolds can be supplied complete with integral steam channels. Entries can be made from the base or rear of the enclosure.

Steam Heating - Coils

Coils are available in copper or stainless steel with access via secure bulkhead connectors.

Electrical Heating - Hazardous Area Heaters

- Slimline panel heaters
- Self limiting type
- ATEX approved equipment

Electrical Heating - Non-Hazardous Area Heaters

Fixed wattage heaters for use in standard industrial areas.

Thermostats

Supplied to suit applications - ATEX approved

Junction Boxes

Supplied to suit applications - ATEX approved



Insulation

For the protection of instruments and other equipment operating in a low temperature environment Sabre enclosures can be fitted with a non-hazardous insulated lining material.

The insulation is constructed from a phenolic foam and metal foil panel and is formed to ensure optimum coverage of the internal surfaces of the enclosure. All edges are sealed to prevent the ingress of hydrocarbons.

Insulation increases the enclosure's heat retention properties and may be combined with a thermostatically controlled heater for greater internal temperature stability, so ensuring instrument accuracy and prolonged performance.

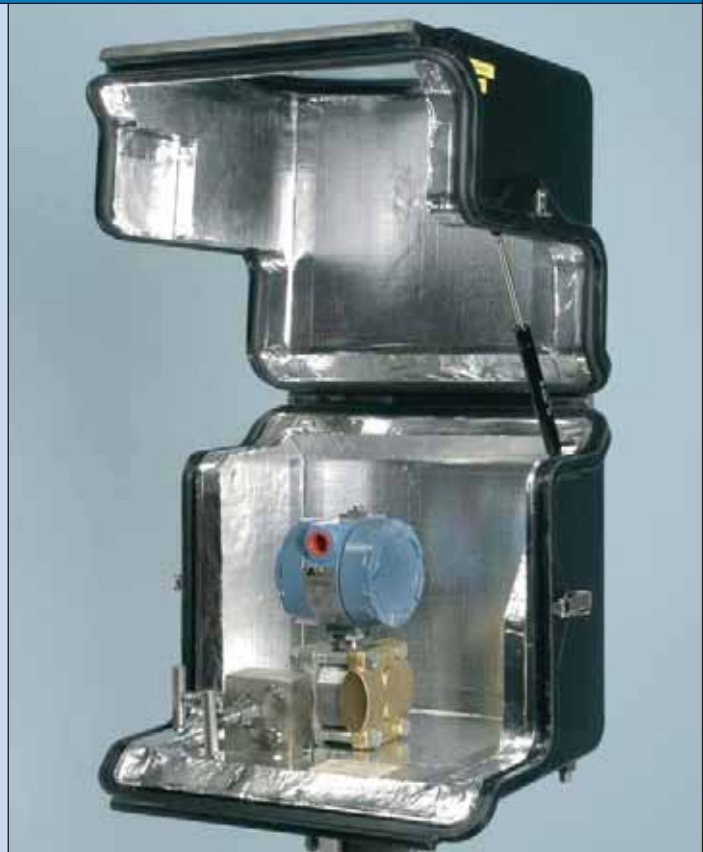

Enclosure Mounting Options

Pipestand Mounting

The IEX enclosures and SX sunshades are supplied as standard with baseplates and collars to suit 2" NB pipestands. The IEX1, IEX2, SX1, SX2 and SX3 require a single pipestand; the IEX3 and SX4 require two. These are available as either 1m and 1.5m standard heights.

Material options include epoxy coated carbon steel, hot dip galvanised steel and stainless steel.

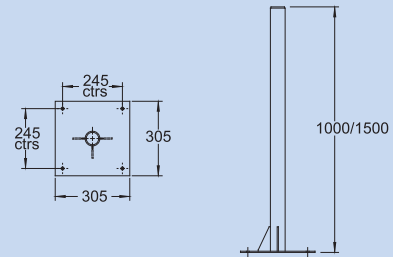

Wall Mounting

The IEX1 enclosures can be supplied with either horizontal or vertical wall mounting brackets. Pipestands and wall mounting brackets are made from epoxy coated carbon steel. Stainless steel is also available.

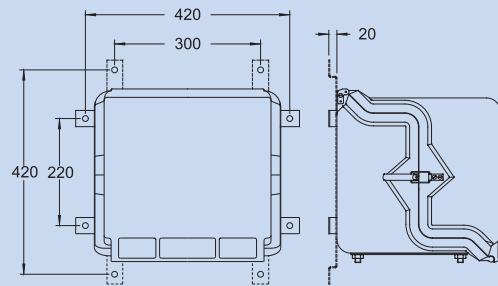

Internal Instrument Mounting

Pipestand Mounting

A standard 2" NB internal pipestand is available for the IEX range of enclosures. A full base internal pipestand is also available.

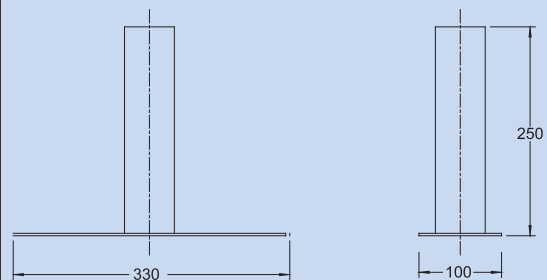

Vertical Mounting Plate

Available as a standard blank or customised to suit particular instruments. Suitable for surface mounting type instruments.

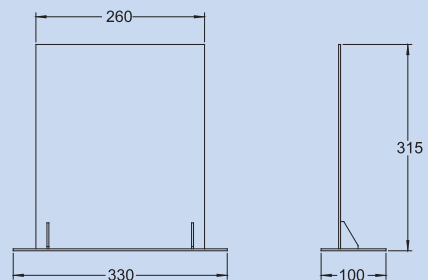

Internal Back Mounting Plate

Available as a blank plate fixed directly to the rear wall of the enclosure to provide reinforcement for instrumentation mounted directly to back of enclosure.

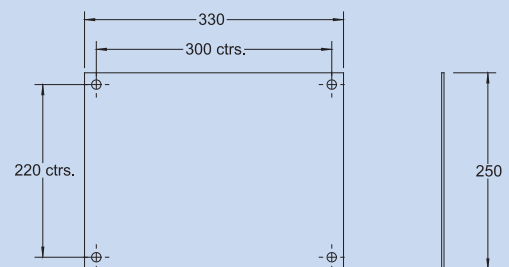

All internal brackets are supplied as standard using epoxy coated carbon steel. Available in stainless steel for more severe environments.

Sabre Sunshades

Features

Sabre Sunshades are designed to protect instruments against adverse environmental conditions as well as mechanical protection from overhead hazards. GRP materials provide robust construction and fire retardance to BS 476 Part 7 Class 2. They are available in a range of sizes to suit a variety of applications and are made as standard in reflective white. Support is provided by integral brackets suitable for standard 2" NB pipe-stand connection.



SX1

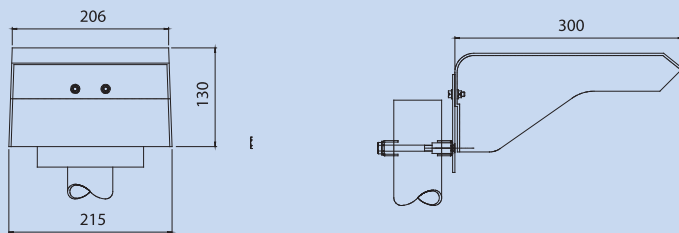

SX2

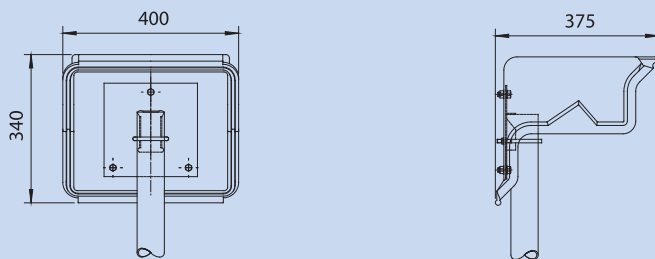

SX3

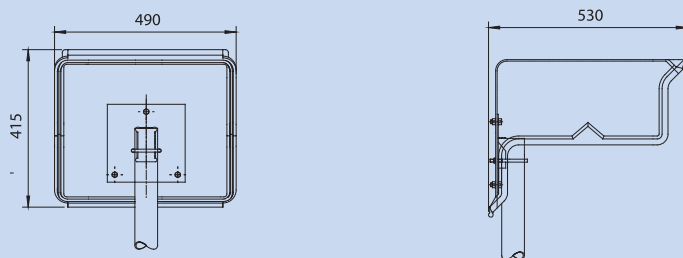

SX4

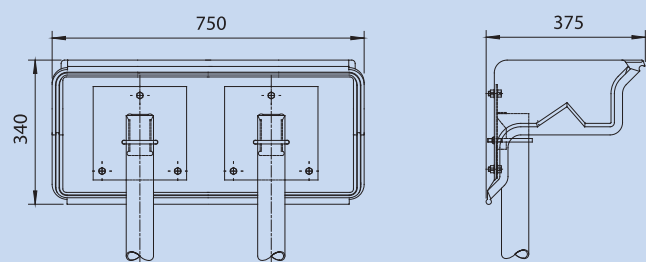

Soft Enclosures Sabre

Introduction

Sabre Soft Enclosures allow for the insulation and protection of equipment where weight, space and access concerns exclude the use of GRP enclosures. Manufactured from Silicone impregnated fibreglass as standard, Soft Enclosures are available in various material thicknesses to suit the particular application conditions. Light weight yet robust construction means that the enclosures are self-supporting, removing the need for costly support frames or brackets. For applications where the internal temperature is to be controlled, electric heaters and associated control equipment can be supplied as an integral part of the enclosure.

Features & Specifications

- Lightweight construction
- Chemical resistant
- Low installation costs
- Custom made to exact size requirements
- Insulation thickness options available of 1/2", 1", 2" and 3"
- Fastening methods - hook & eye, stainless steel lacing hooks and clinch belts
- Integral Viewing Window options available

Applications

- Instrument Housings
- Indicators
- Strainers
- Transmitters
- Valves
- Steam Traps
- Transducers
- Vessels
- Pumps
- Flowmeters
- Gauges
- Flanges



Sabre Enclosure System

Enclosure System Options



IEX3 Enclosure with window and transmitters



IEX3 Enclosure with transmitters and gauge



IEX1 Enclosures with integral manifolds and transmitters

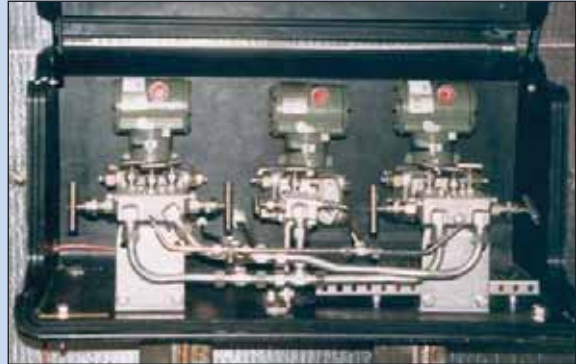

IEX3 Antistatic Enclosure with transmitters



IEX3 Enclosure with heating system



IEX3 Enclosure with heating system and insulation



IEX2 Antistatic Enclosure with integral manifold and insulation



Customer specific colours



IEX1 Enclosure with integral manifold and transmitter

Model Numbering System

Enclosure Model Number:

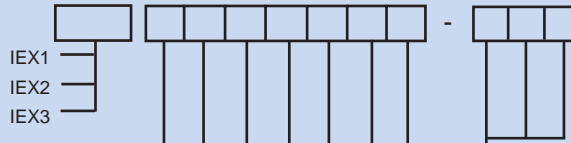

Enclosure Type

- Standard construction
- Antistatic construction
- Non standard colour
- Insulation
- Non standard colour insulated
- Antistatic insulated
- Antistatic / St-Stl Gas Strut & 316SS Toggles
- Antistatic / St-Stl Gas Strut & 304SS Toggles
- Other

- A
- B
- C
- D
- E
- F
- G
- H
- Z

Manifold Type

- None required
- HMX2/HMX3 Manifold
- HMX2/HMX5 Manifold
- HMX3/HMX5 Manifold
- HMX2 Manifold
- HMX3 Manifold
- HMX5 Manifold
- HMX2 LH & HMX2 RH
- HMX2 LH & HMX2 RH & HMX2
- HMX2 LH & HMX2 RH & HMX3
- HMX2 LH & HMX2 RH & HMX5
- HMX2 G^{1/2}" top
- HMX2 ^{1/2}" npt top
- HMX1
- Other

- A
- B
- C
- D
- E
- F
- G
- I
- J
- K
- L
- M
- N
- P
- Z

Enclosure Mounting

- None required
- Baseplate for 2" NB pipestand - CS
- Backplate for 2" NB pipestand - CS
- Horizontal mounting straps - CS
- Vertical mounting straps - CS
- Baseplate for 2" NB pipestand - 304SS
- Backplate for 2" NB pipestand - 304SS
- Horizontal mounting straps - 304SS
- Vertical mounting straps - 304SS
- Baseplate for 2" NB pipestand - 316SS
- Other

- A
- B
- C
- D
- E
- F
- G
- H
- I
- J
- Z

Enclosure Entries

- None required
- Grommets
- Cable glands
- Gland plate & split gland plate
- Gland plate
- Low back mtg
- High back mtg
- Split gland plate
- Low back mtg & gland plate
- Gland plate c/w grommet
- Gland plate c/w cable gland
- Other

- A
- B
- C
- D
- E
- F
- G
- H
- I
- J
- K
- Z

Accessories

- A Handle
- B Stainless steel tag
- C Traffolyte tag
- D Thermostat
- E Junction box
- F Padlock bracket
- G Ventilator
- H Louvres
- I External pipestand
- J Gauge adaptor
- K Vertical flange adaptor
- L Male adaptor
- M Drain
- N Level indicator
- O Kidney flanges
- P M10 bolts
- Q Tranberg drain
- R Pipe fittings
- Z Other

Heating

- A None required
- B Steam coil
- C Integral with manifold
- D Electrical non-hazardous area
- E Electrical hazardous area
- Z Other

Internal Mounting

- A None required
- B 2" NB pipestand - CS
- C Back mounting plate - CS
- D Vertical mounting plate - CS
- E 2" NB pipestand - 304SS
- F Back mounting plate - 304SS
- G Vertical mounting plate - 304SS
- H Special mtg plate/bracket
- I Horizontal mtg plate
- J BMP & special mtg plate/bracket
- K 2" NB Pipestand - 316SS
- Z Other

Windows

- A None required
- B Front acrylic
- C Front reinforced glass
- D Non standard acrylic
- E Non standard reinforced glass
- Z Other

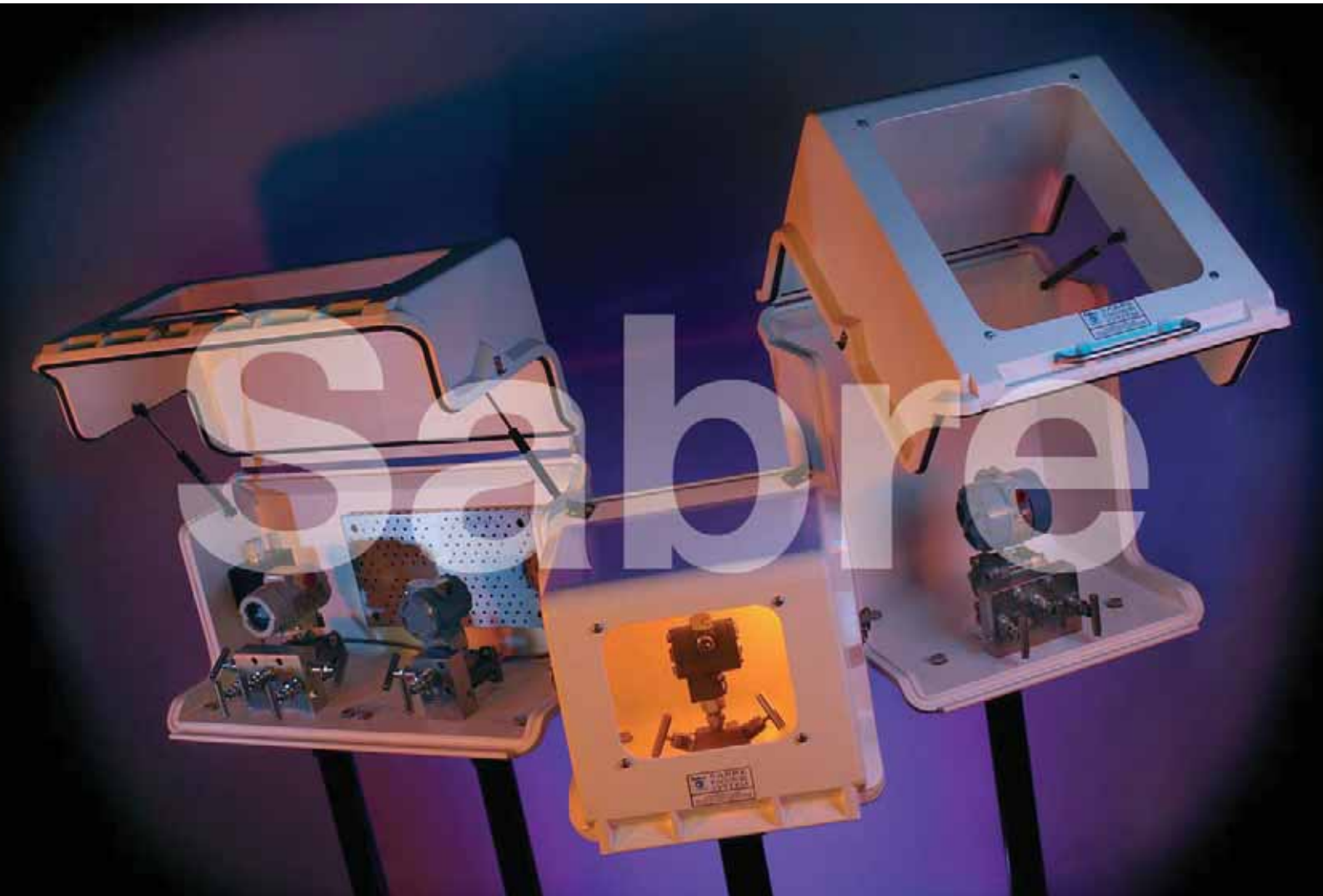

Certificate No. FM 32559
ISO 9001
Quality Management



Certificate No. OHS 94148
ISO 18001
Occupational Health & Safety



Sabre Instrument Valves Limited

Golf Road, Hale, Altrincham,
Cheshire WA15 8AH
United Kingdom

Tel: +44(0)161 925 4000

Fax: +44(0)161 925 4001

E-mail: valves@sabreuk.com



Certificate No. EMS 54826
ISO 14001
Environmental



For further product details and Standard Terms and Conditions of Sale visit:
www.sabre-valves.com